

∅172 IG series

x150x38mm



General Specifications

- Motor : Singal phase induction capacitor motor
- Frame & Impller : Metal
- Storage temperature : -40°C to +75°C
- Operating temperature : -10°C to +70°C

Major Characteristic Parameters

Model	Bearing System	Rated Voltage	Freq.	Power Input	Rated Speed	Maximum Air Flow	Maximum Static Pressure	Sound Level	Weight		
Part NO.	B / S	V	Hz	W	RPM	m ³ /min	CFM	mm-H ₂ O	In-H ₂ O	dBA	Kg
IGE17238B1H	B / S	110	50/60	27/28	2800/3200	5.38/6.34	190/224	14.5/17.8	0.57/0.70	53/57	0.84
IGE17238B2H	B / S	230	50/60	27/28	2800/3200	5.38/6.34	190/224	14.5/17.8	0.57/0.70	53/57	0.84

*Bearing system B: Two Ball Bearing

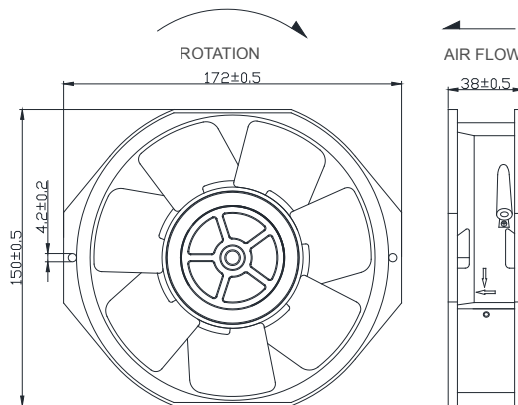
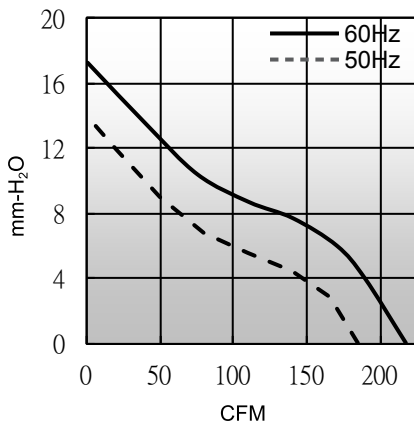

unit:mm